

## 2 - Hood/Tank

CODE	DESCRIPTION
120348	MAGN.SWITCH (N.O.)
150819	CABLE HOLDER PG16 WITH HOLE
160811	WASHER F2 18X8.5X1 ALGOF
160907	CONNECTION FOR TABLES C95-155
180642	GUIDE
190637	GUIDE FOR DOOR "C"
190638	ROLLER FOR "C" DOOR GUIDE
200925	GASKET
200957	GASKET
200964	GASKET 618X14 SP.2
260113	STAINL.ST.TE SCREW 8X20 A2 UNI
260219	STAINL.ST TCP SCREW 6X35 A2 UN
260224	TB-SCREW 6X15 B23-10-11-12
260329	VITE M5X12 SPEC.ZIGR.SOTTOTEST
260404	STAINLESS STEEL NUTS D6 UNI 55
260504	ST/ST FLAT WASHER D6
260505	STAINL.STEEL FLAT WASHER D8
260512	ST/ST GROWER WASHER D6
260513	GROWER WASHER D8
260538	WASHER 18X6X1,5 ST/ST
260543	WASHER D.6 ST/ST
261015	SCREW 3,9X13
320534	LOWER FRAME
324011	GUIDE FOR 530238
324016	SWITCH BRACKET
332424	SQUADRETTA SOST.TUBO PRESS.C
342257	TANK
342497	HOOD
342498	INSULATED HOOD
351421	LEFT PANEL
351422	RIGHT PANEL
351767	FRONT PANEL
351832	PANNELLO FRONT.LC CON TERMOM.
351869	FRONT PANEL WITH THERMOMETERS
390182	BACK PANEL
440211	LEGS
530238	RACK SUPPORT C-SERIES

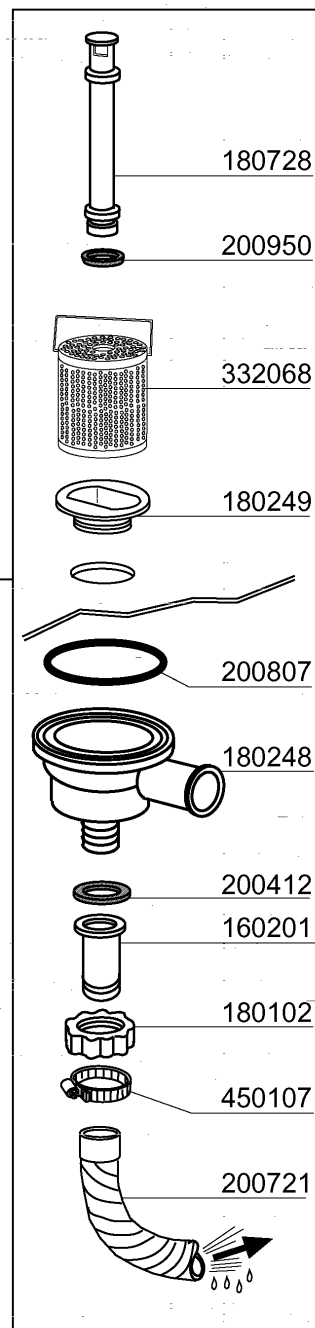
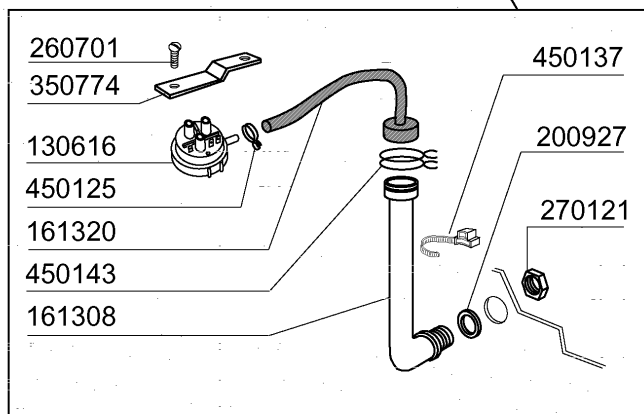
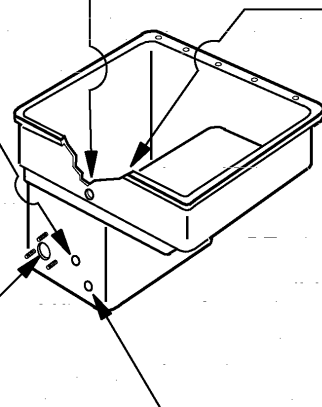
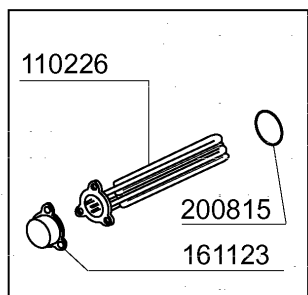
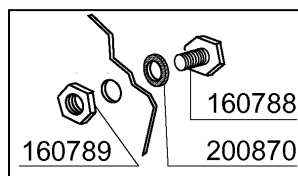
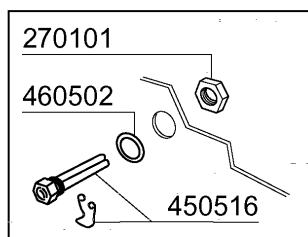
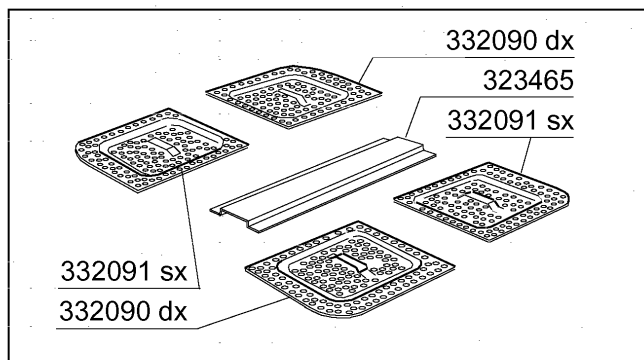

**3 - Tank**

<b>CODE</b>	<b>DESCRIPTION</b>
110226	HEAT. ELEMENT 3000W 230/400V
130616	PRESSURE SWITCH 190/80 FOR C95
160201	ELBOW F.TANK INLET MOPLN
160788	PLUG
160789	NUT
161123	HEAT.ELEMENT COVER H42 SNL
161308	AIR CHAMBER C95-155
161320	HOSE FOR AIR CHAMBER
180102	DRAIN PIPE NUT 1"1/2 F45-55
180248	SUCTION TANK
180249	NUT
180728	OVERFLOW PIPE
200412	GASKET DRAIN 11/2" 45X33X3
200721	DRAIN HOSE 28X35 2MT.
200807	O-RING 3,53 X 110,72
200815	O-RING F. HEAT.ELEM.
200870	GASKET 18X10X2
200927	GASKET FOR AIR TRAP
200950	VITON GASKET
260701	SCREW 3,5X9,5
270101	HEXAGON LOCK NUT 1/2"
270121	NUT FOR AIR TRAP
323465	STRAINERS SUPPORT
332068	STRAINER
332090	RIGHT STRAINER
332091	TANK LEFT STRAINER
350774	BRACKET
450107	CLAMP FE ZN 38-50 H=12,2
450125	ELASTIC CLAMP D. 10,4X9,8
450137	COLLAR CONNECTION WITH BASE 31
450143	CLAMP D.39,7 X 37,7
450516	THERMOSTAT SHIELD FOR 2 TERMOS
460502	GASKET 30X21X2

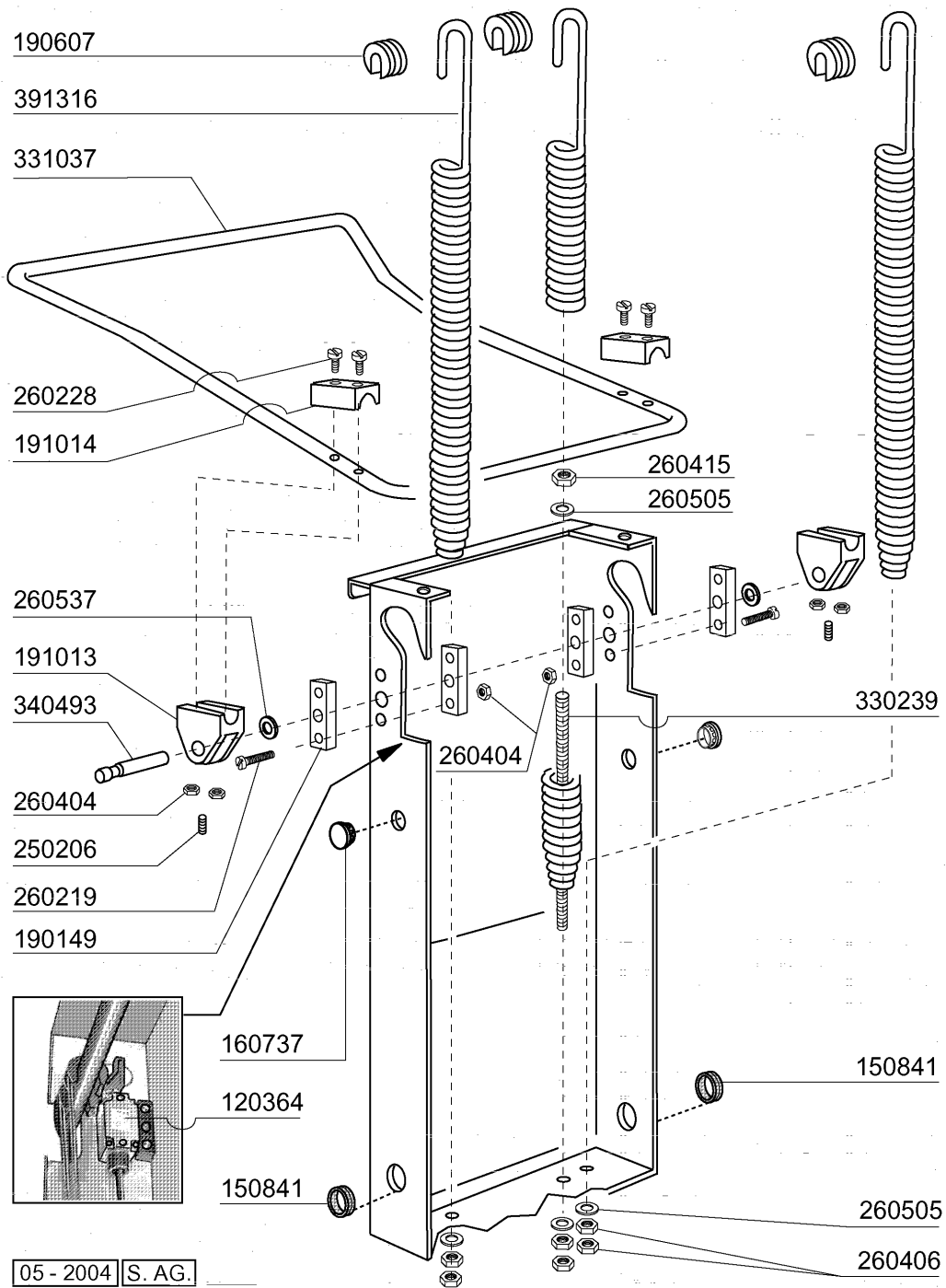

05 - 2004 | S. AG.

**4 - Handle**

<b>CODE</b>	<b>DESCRIPTION</b>
120364	LIMIT SWITCH WITH LEVER
150841	CABLE HOLDER
160737	PLUG HEYCO D.34,9
190149	REINFORCEMENT FOR HANDLE SUPP.
190607	HANDLE BUSH C30-70
191013	HINGE F. SUPPORT C30-C70
191014	FLANGE F. HANDLE C30-70
250206	GRUB SCREW D.6
260219	STAINL.ST TCP SCREW 6X35 A2 UN
260228	STAINL.ST SPECIAL SCREW 6X42 3
260404	STAINLESS STEEL NUTS D6 UNI 55
260406	NUT 8MA
260415	STAINLESS STEEL SELF-LOCKING N
260505	STAINL.STEEL FLAT WASHER D8
260537	STAINL.STEEL FLAT WASHER D13X2
330239	ROD
331037	HANDLE C95-155-165 ISOLATED
340493	PIN F. HINGE C30
391316	SPRING FOR HANDLE C85/140-G75



## 5 - Wash/Rinse column

CODE	DESCRIPTION
180248	SUCTION TANK
180413	TEE NIPPLE D.11,5 - RINSE ASSE
190227	ARM SUPPORT
190674	BUSH
191100	RINSE COLLECTOR C-LC
200122	HOSE 11X19
200482	GASKET 60X54 RAMP C140
200955	GASKET
201057	WASH PUMP INLET HOSE
201058	OUTLET HOSE
260102	SCREW TE 6X10
260126	SCREW TE 5X12
260151	SCREW TE 4X12
260404	STAINLESS STEEL NUTS D6 UNI 55
260502	S/S FLAT WASHER D.4
260510	GROWER WASHER D.4
260511	GROWER WASHER D.5
260512	ST/ST GROWER WASHER D6
260513	GROWER WASHER D8
260538	WASHER 18X6X1,5 ST/ST
332526	RINSE HOSE
344000	PUMP SUPPORT
420423	WASH RAMP C/LC
441111	PUMP FEET 25X25XM6
450103	CLAMP FE ZN. 13-20 H=9
450119	CLAMP FE ZN. 58-75 H=12,2



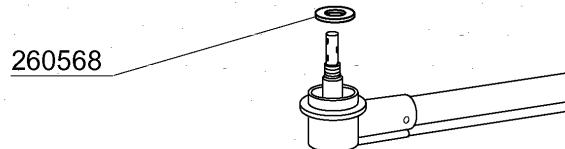
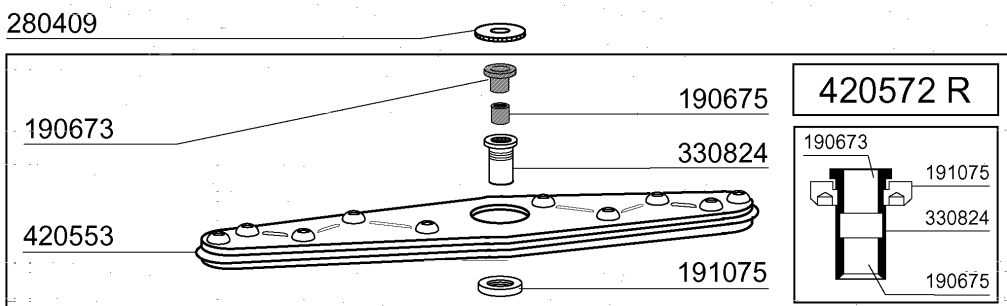
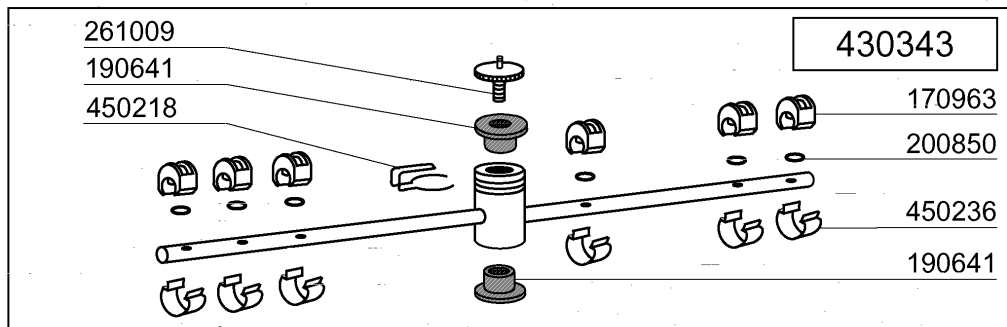
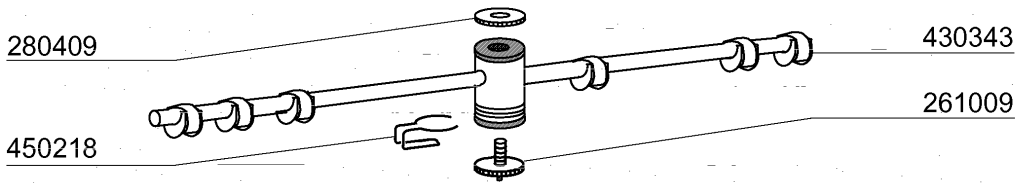
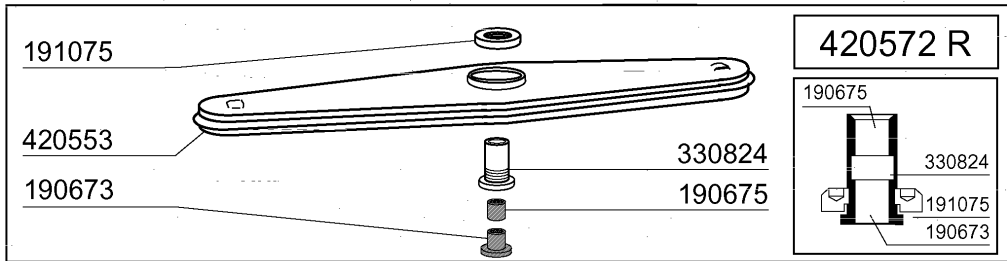
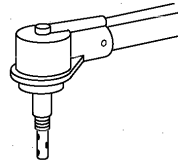

**6 - Wash arm**

<b>CODE</b>	<b>DESCRIPTION</b>
170963	RINSE JET X FC
190641	BUSH FOR C95-155-165 RINSE ARM
190673	BUSH
190675	BUSH
191075	RETAIN.LOCK
200850	O-RING
260568	S/S FLAT WASHER D.28X21X1
261009	RETAIN.SCREW FOR WASH-RINSE AR
280409	RETAIN.LOCK NUT CENTR.CROSS C1
330824	WASH ARM CENTER (STAINL.)
420553	S/STEEL WASH ARM - 420572R
420572R	WASH ARM LC
430343	RINSE ARM LC700/900/1200
450218	SPRING F.RINSE ARM RETAIN.SCRE
450236	SPRING FOR WASHER 170963

7 - Rinse Assembly / Thermostat

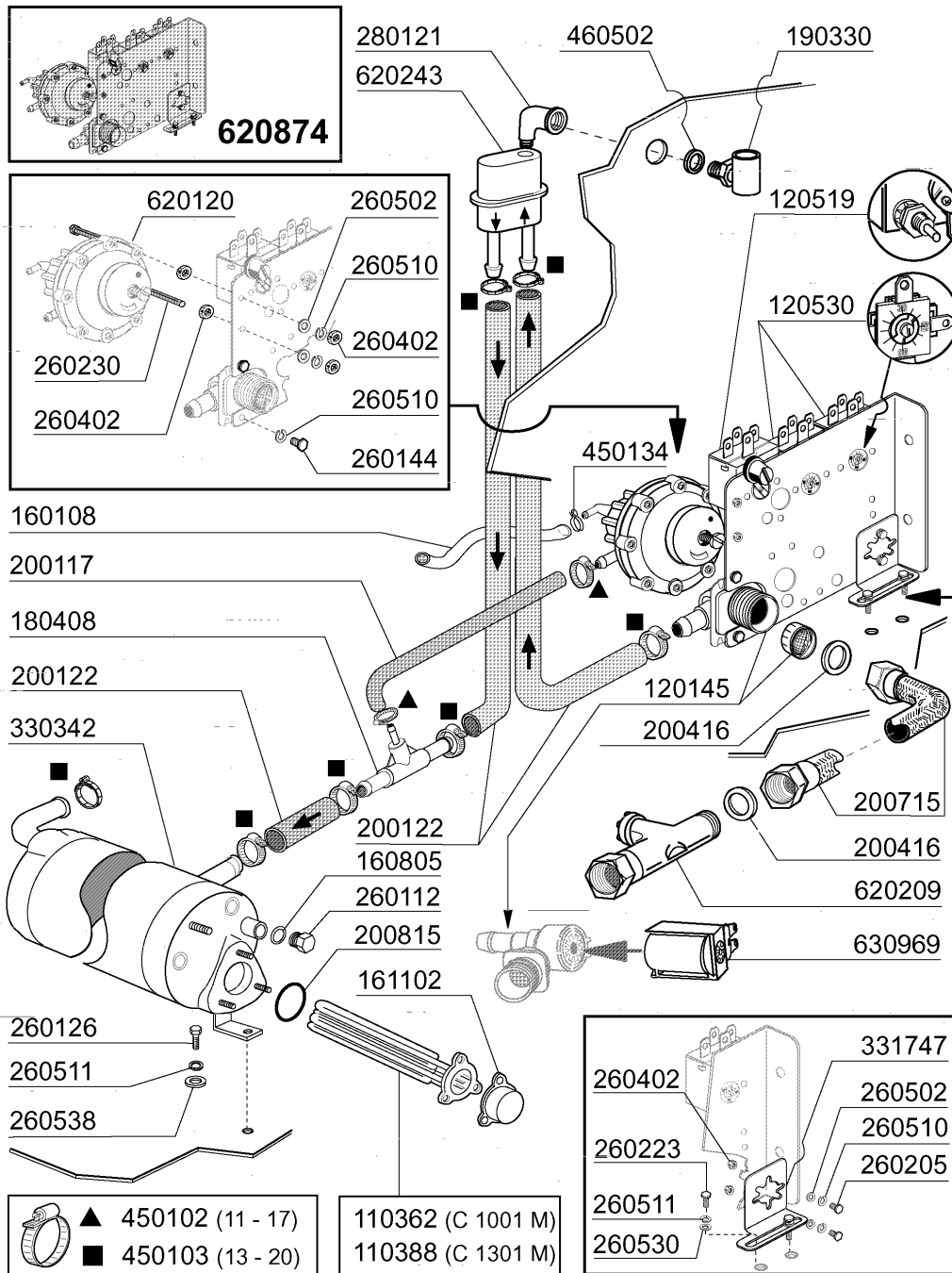

05 - 2004 | S. AG.

## 7 - Rinse Assembly / Thermostat

CODE	DESCRIPTION
110362	HEAT.ELEMENT 9000W 220/380V
110388	HEAT.ELEMENT 10000W 230/400V
120145	SOLENOID VALVE 12 LT 1 WAY
120519	SECURITY THERMOSTAT 95-125Ø
120530	THERMOSTAT 0-90Ø
160108	INJECT.INLET HOSE D.8X5
160805	GASKET D.8
161102	ELEMENT COVER MOPL.
180408	TEE-NIPPLE F.INJECT.W/CENTR.RE
190330	TEE FOR VAACUM BREAKER
200117	RUBBER HOSE 7X16
200122	HOSE 11X19
200416	GASKET D. 3/4"
200715	HOSE WATER INLET 2M STAINL.ST
200815	O-RING F. HEAT.ELEM.
260112	STAINLESS STEEL TE-SCREW 8X16
260126	SCREW TE 5X12
260144	SCREW TE 4X6
260205	SCREW TCP 4X16
260223	M5X12 MSH/HD SCREW SPECIAL S/S
260230	SCREW TCP 4X40
260402	STAINLESS STEEL NUT D4 UNI 55
260502	S/S FLAT WASHER D.4
260510	GROWER WASHER D.4
260511	GROWER WASHER D.5
260530	STAINL.ST WASHER 7X22X2
260538	WASHER 18X6X1,5 ST/ST
280121	ELL FOR VAACUM BREAKER
330342	BOILER C95-C155-C165
331747	SQUADR.SX X COMP.C1001-1301M
450102	CLAMP FE ZN 11-17 H=9
450103	CLAMP FE ZN. 13-20 H=9
450134	ELASTIC HOSE CLIP D.9,3/8,8
460502	GASKET 30X21X2
620120	RINSE AID INJECTOR
620209	INLET WATER FILTER
620243	VACUUM BREAKER (WITHOUT KIT)
620874	ASSIEME COMPONENTI C1001-1301M
630969	COIL S4216 220/50HZ

## 8 - Rinse Assembly / Thermostat

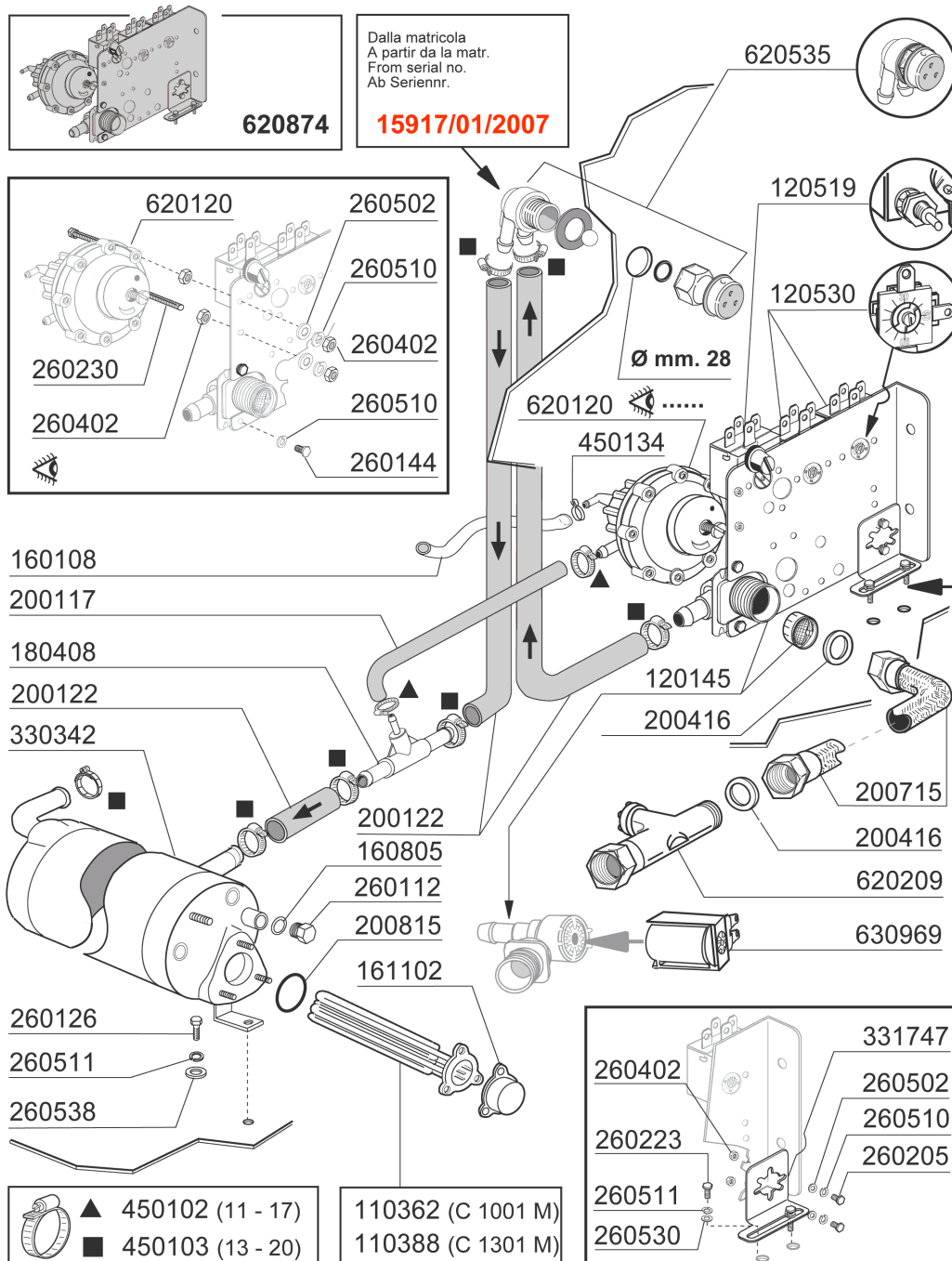

02 - 2007 | S. AG.

## 8 - Rinse Assembly / Thermostat

CODE	DESCRIPTION
110362	HEAT.ELEMENT 9000W 220/380V
110388	HEAT.ELEMENT 10000W 230/400V
120145	SOLENOID VALVE 12 LT 1 WAY
120519	SECURITY THERMOSTAT 95-125Ø
120530	THERMOSTAT 0-90Ø
160108	INJECT.INLET HOSE D.8X5
160805	GASKET D.8
161102	ELEMENT COVER MOPL.
180408	TEE-NIPPLE F.INJECT.W/CENTR.RE
200117	RUBBER HOSE 7X16
200122	HOSE 11X19
200416	GASKET D. 3/4"
200715	HOSE WATER INLET 2M STAINL.ST
200815	O-RING F. HEAT.ELEM.
260112	STAINLESS STEEL TE-SCREW 8X16
260126	SCREW TE 5X12
260144	SCREW TE 4X6
260205	SCREW TCP 4X16
260223	M5X12 MSH/HD SCREW SPECIAL S/S
260230	SCREW TCP 4X40
260402	STAINLESS STEEL NUT D4 UNI 55
260502	S/S FLAT WASHER D.4
260510	GROWER WASHER D.4
260511	GROWER WASHER D.5
260530	STAINL.ST WASHER 7X22X2
260538	WASHER 18X6X1,5 ST/ST
330342	BOILER C95-C155-C165
331747	SQUADR.SX X COMP.C1001-1301M
450102	CLAMP FE ZN 11-17 H=9
450103	CLAMP FE ZN. 13-20 H=9
450134	ELASTIC HOSE CLIP D.9,3/8,8
620120	RINSE AID INJECTOR
620209	INLET WATER FILTER
620535	VACUUM BREAKER
620874	ASSIEME COMPONENTI C1001-1301M
630969	COIL S4216 220/50HZ

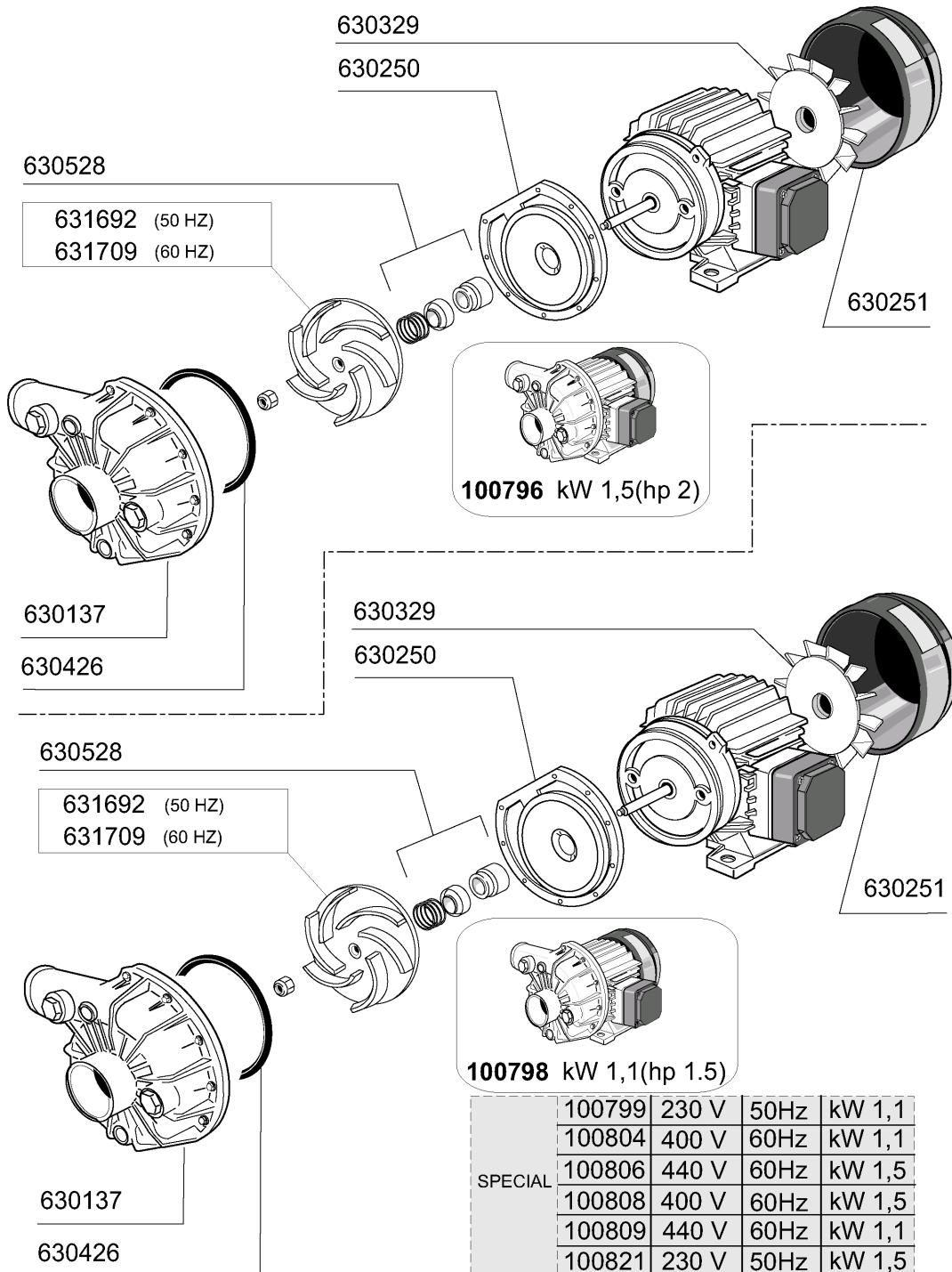

05 - 2009 | M.SA.

**9 - Wash pump**

<b>CODE</b>	<b>DESCRIPTION</b>
100796	PUMP 2HP 400/3/50HZ LGB
100798	PUMP 1,5HP LGB
100799	PUMP HP1,5-230/50
100804	PUMP 1,5HP 220/3/60
100806	PUMP 2HP 440V/3 60HZ
100808	PUMP HP 2 380/3/60
100809	PUMP HP 1,5 440/3/60
100821	PUMP HP 2 230/1/50
630137	PUMP VOLUTE LGB ZF800DX
630250	BACK PLATE PUMP ZF650/800
630251	FAN HOUSING ZF650/800
630329	PUMP FAN IMPELLOR ZF650/800
630426	GASKET LGB ZF800
630528	SEAL LGB ZF800 2HP
631692	IMPELLER PUMP ZF650/800
631709	PUMP IMPELLER ZF800 60HZ



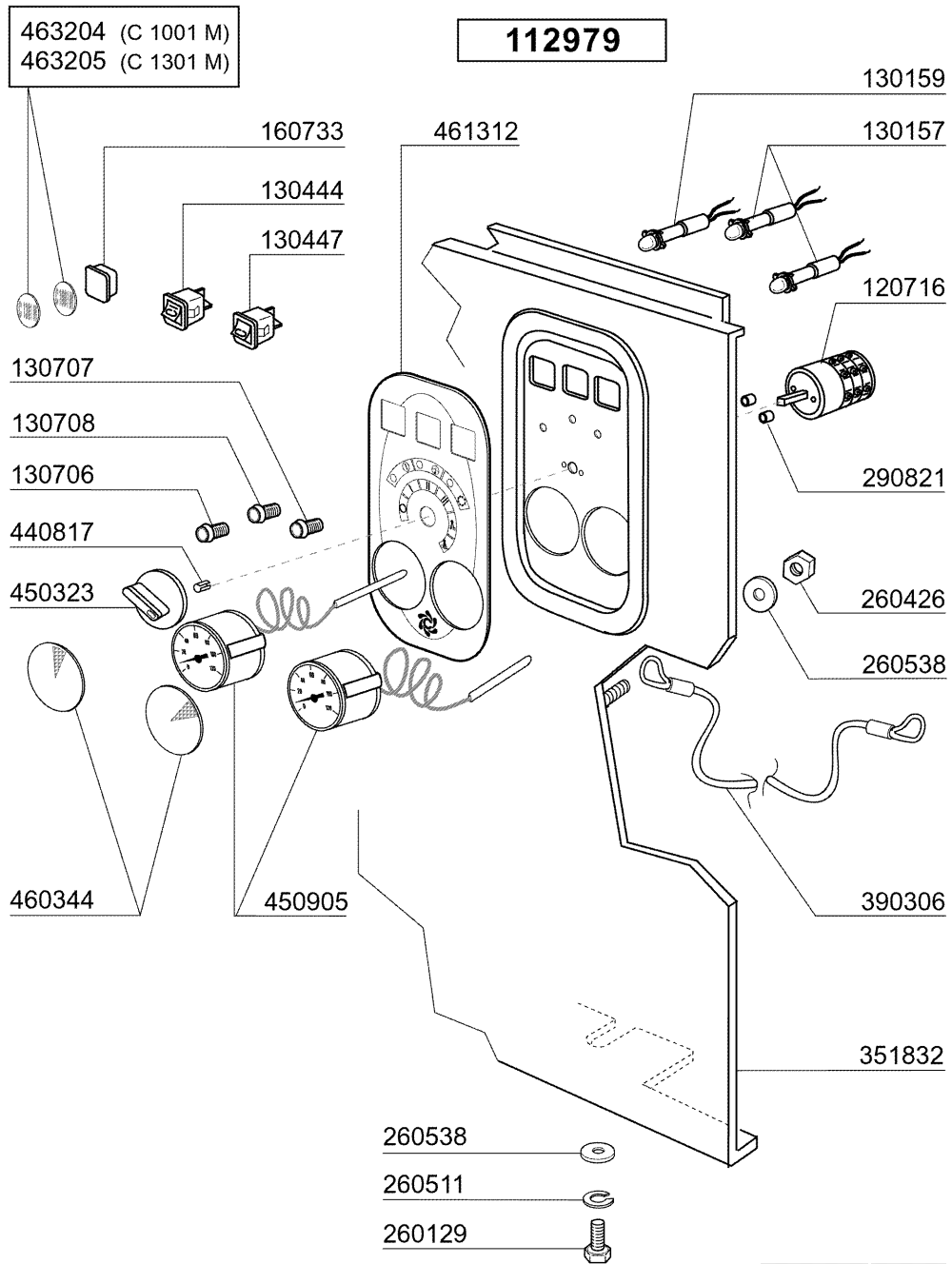

05 - 2004 | S. AG.

**10 - Control panel**

<b>CODE</b>	<b>DESCRIPTION</b>
112979	WIRHNG
120716	6 POLES SWITCH 16A
130157	GREEN LED FOR BR-BC-C-SERIES -
130159	ORANGE LED FOR C-SERIES - 220V
130444	SWITCH "START CYCLE" F
130447	CYCLE START SELECTOR FOR C-SER
130706	ORANGE LENS COVERS (C-SERIES)
130707	TRANSPARENT LENS COVERS (C-SER
130708	GREEN LENS COVERS (C-SERIES)
160733	BLANK PLATES
260129	SCREW TE M 5X20
260426	DADI ESAG.CIECHI INOX "M6"
260511	GROWER WASHER D.5
260538	WASHER 18X6X1,5 ST/ST
290821	DISTANCE PIECE FOR SWITCH
351832	PANNELLO FRONT.LC CON TERMOM.
390306	CABLE
440817	SNAP RING LSCB/1853/17/00
450323	KNOB FOR BC-BR-C95-C155
450905	CAPIL.THERMOMETER D.52 1,5M
460344	PLATE
461312	CONTROL PANEL
463204	C1001M PLATE
463205	C1301M PLATE

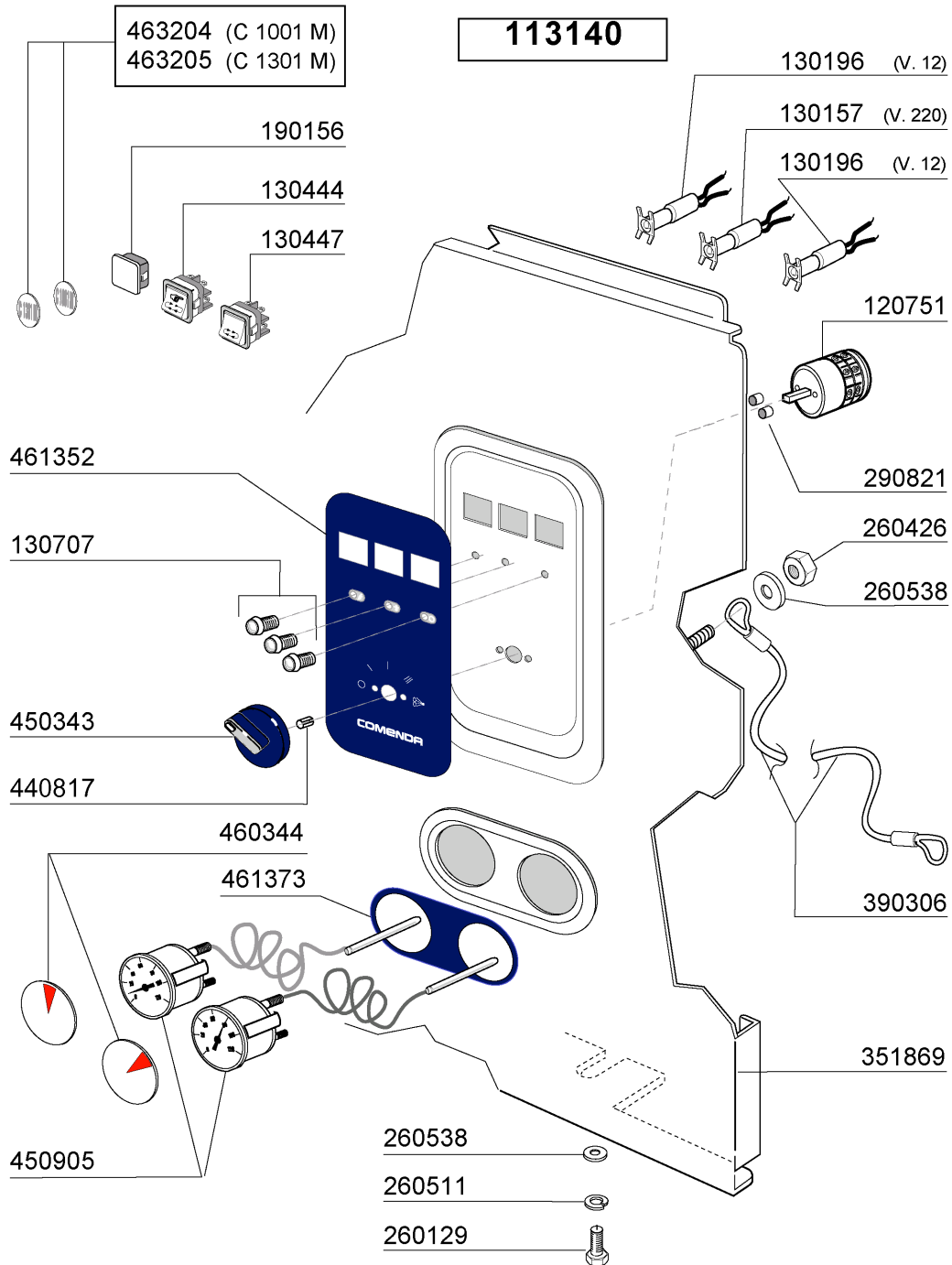

## 11 - Control panel

CODE	DESCRIPTION
113140	COMPLETE CONTROL PANEL
120751	4 POLE SWITCH 16A
130157	GREEN LED FOR BR-BC-C-SERIES -
130196	GREEN LAMP
130444	SWITCH "START CYCLE" F
130447	CYCLE START SELECTOR FOR C-SER
130707	TRANSPARENT LENS COVERS (C-SER
190156	PLUG
260129	SCREW TE M 5X20
260426	DADI ESAG.CIECHI INOX "M6"
260511	GROWER WASHER D.5
260538	WASHER 18X6X1,5 ST/ST
290821	DISTANCE PIECE FOR SWITCH
351869	FRONT PANEL WITH THERMOMETERS
390306	CABLE
440817	SNAP RING LSCB/1853/17/00
450343	BLUE SWITCH
450905	CAPIL.THERMOMETER D.52 1,5M
460344	PLATE
461352	LC2004 PLATE
461373	SELF ADHESIVE SYMBOL
463204	C1001M PLATE
463205	C1301M PLATE

**113017** (C 1001 M)

**113018** (C 1301 M)

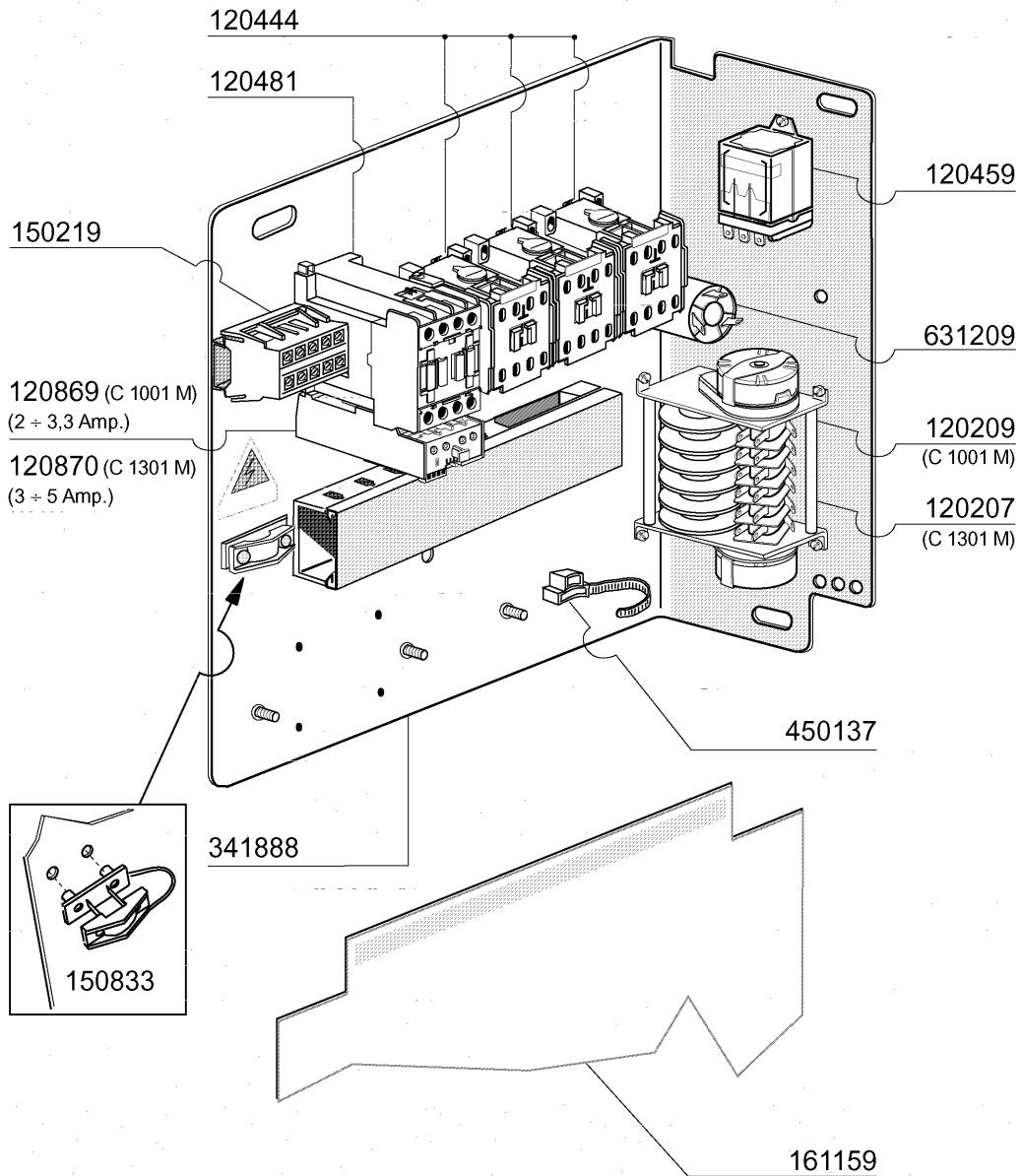

05 - 2005 | S. AG.

## 12 - Control Box

CODE	DESCRIPTION
113017	IMP.EL.C1001M
113018	IMP.EL.C1301M
120207	TIMER 2M 50/90/120
120209	TIMER 2M 65/100/150
120444	CONTACTOR 9A 220V 50HZ
120459	AUXIL.RELE 16A 220V
120481	CONTACTOR 9A-230V 50/60HZ
120869	OVERLOAD RELAY 2/3,3
120870	OVERLOAD RELAY 3/5
150219	TERMINAL BLOCK 5P MMQ165VD26
150833	CABLE HOLDER BC/BR
161159	PROTECT. COMMANDS SWITCHBOARD
341888	CONTROL BOX SUPPORT
450137	COLLAR CONNECTION WITH BASE 31
631209	ANTI-NOISE FILTER

**113081** (C 1001 M)

**113082** (C 1301 M)

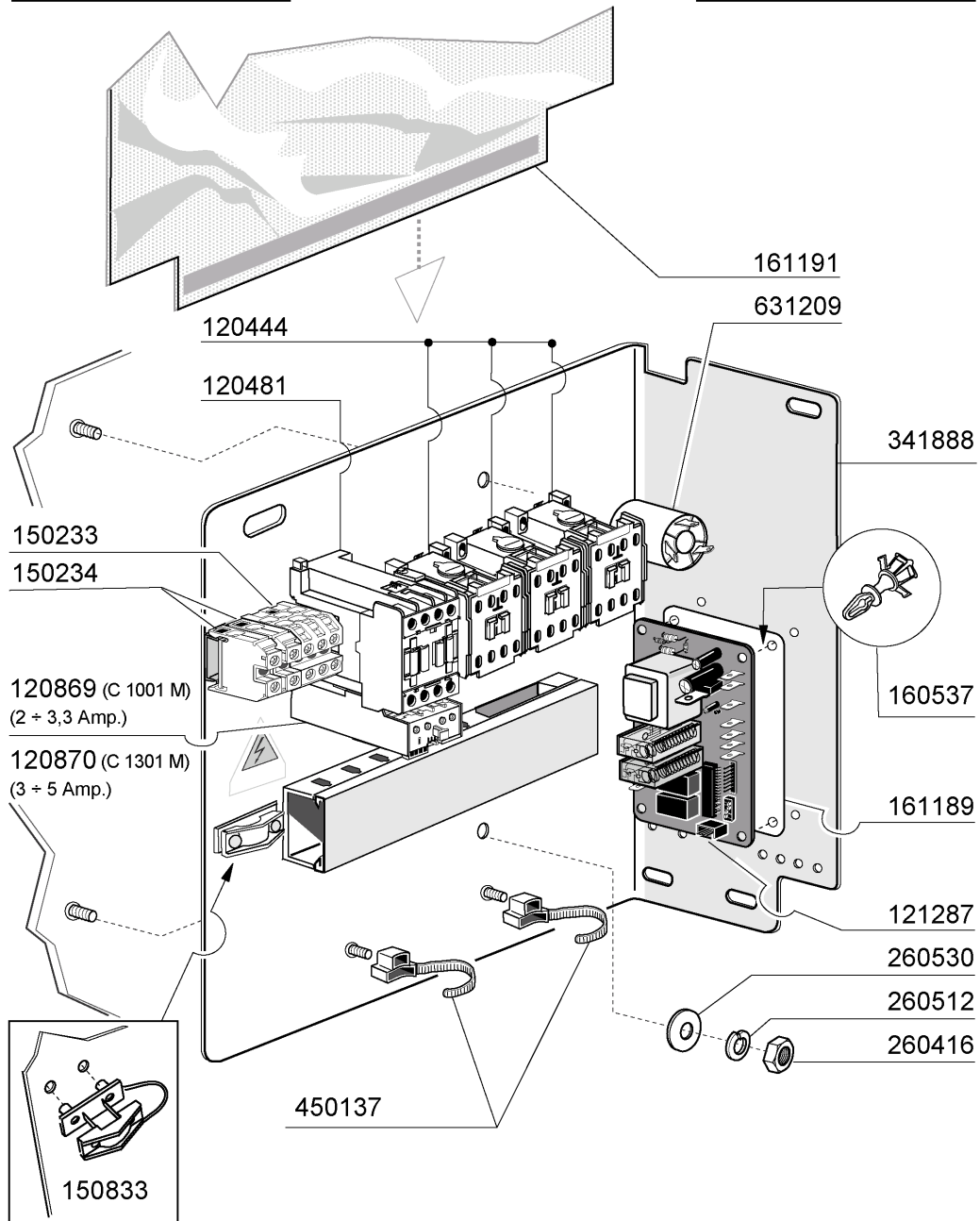

04 - 2007 | S. AG.

## 13 - Control Box

<b>CODE</b>	<b>DESCRIPTION</b>
113081	IMP.EL.LC900
113082	IMP.EL.C1301M 04
120444	CONTACTOR 9A 220V 50HZ
120481	CONTACTOR 9A-230V 50/60HZ
120869	OVERLOAD RELAY 2/3,3
120870	OVERLOAD RELAY 3/5
121287	ELECTRONIC TIMER
150233	TERMINAL BLOCK
150234	TERMINAL BLOCK
150833	CABLE HOLDER BC/BR
160537	ELECTRONIC CARD SPACER
161189	COVER
161191	CONTROL BOX COVER
260416	STAINLESS STEEL NUTS M6
260512	ST/ST GROWER WASHER D6
260530	STAINL.ST WASHER 7X22X2
341888	CONTROL BOX SUPPORT
450137	COLLAR CONNECTION WITH BASE 31
631209	ANTI-NOISE FILTER



14 - Rinse aid injector

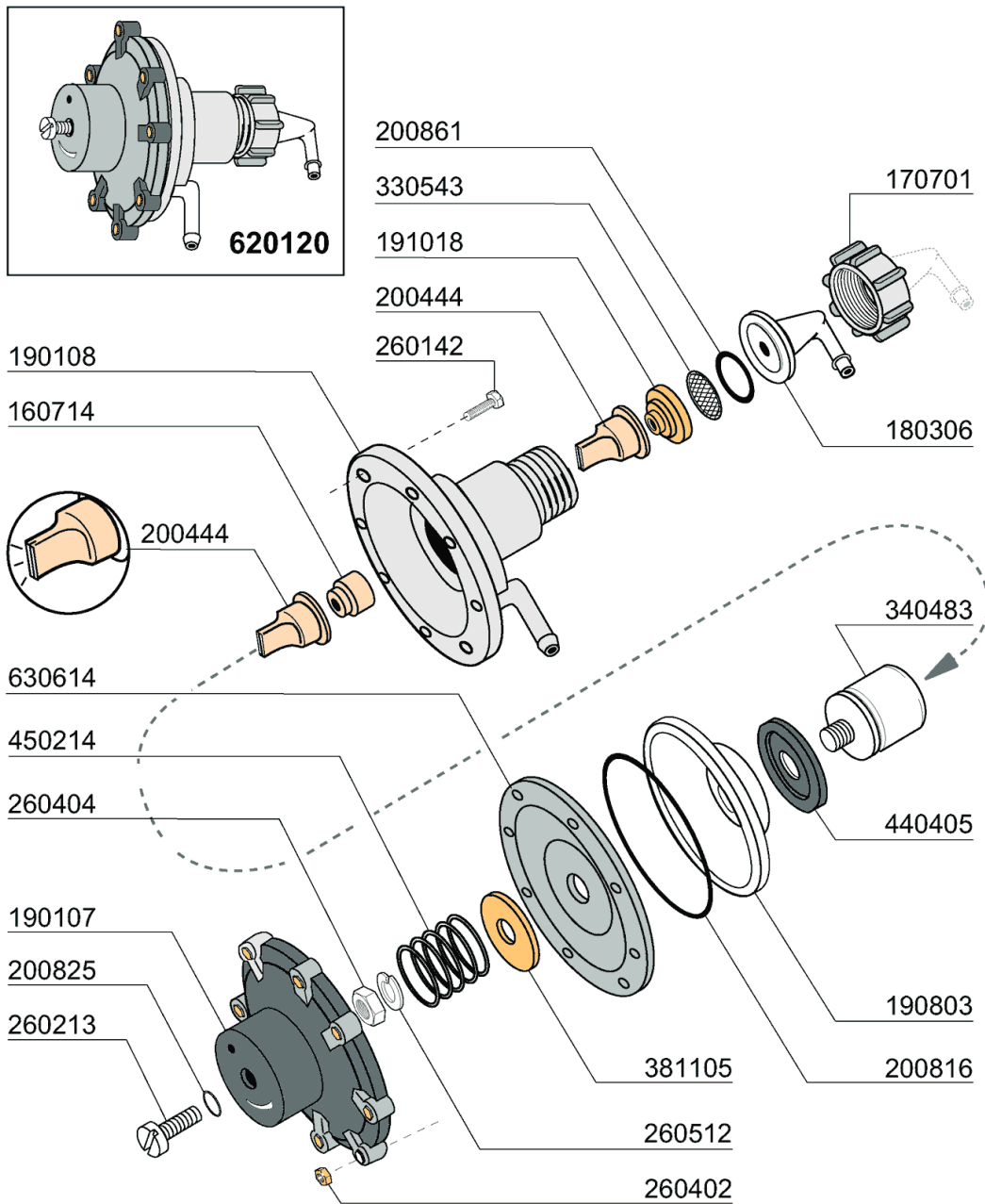

09 - 2007 | S. AG.

14 - Rinse aid injector

CODE	DESCRIPTION
160714	PLUG FOR RINSE AID INJECTOR MO
170701	LOCK NUT 1/2" F.INJECTOR
180306	NIPPLE F.RINSE AID INJECTOR
190107	COVER FOR RINSE AID DISPENSER
190108	VOLUTE FOR RINSE AID DISPENSER
190803	GASKET SUPPORT RING F.INJECT
191018	FILTER SUPPORT RINSE AID INJEC
200444	SUCTION VALVE RINSE INJECTOR
200816	O-RING 2,5X59,2X64,2 RINSE INJ
200825	O-RING 3X5X11 RINSE INJECTOR
200861	O-RING 14X18X2
260142	SCREW TE 4X16
260213	SCREW TCP 5X25
260402	STAINLESS STEEL NUT D4 UNI 55
260404	STAINLESS STEEL NUTS D6 UNI 55
260512	ST/ST GROWER WASHER D6
330543	FILTER RINSE AID INJECTOR D.17
340483	PISTON FOR RINSE AID DISPENSER
381105	DIAPHRAGME DISC
440405	GASKET FOR RINSE AID INJ.
450214	SPRING RINSE AID INJECTOR
620120	RINSE AID INJECTOR
630614	DIAPHRAGM RINSE INJECTOR

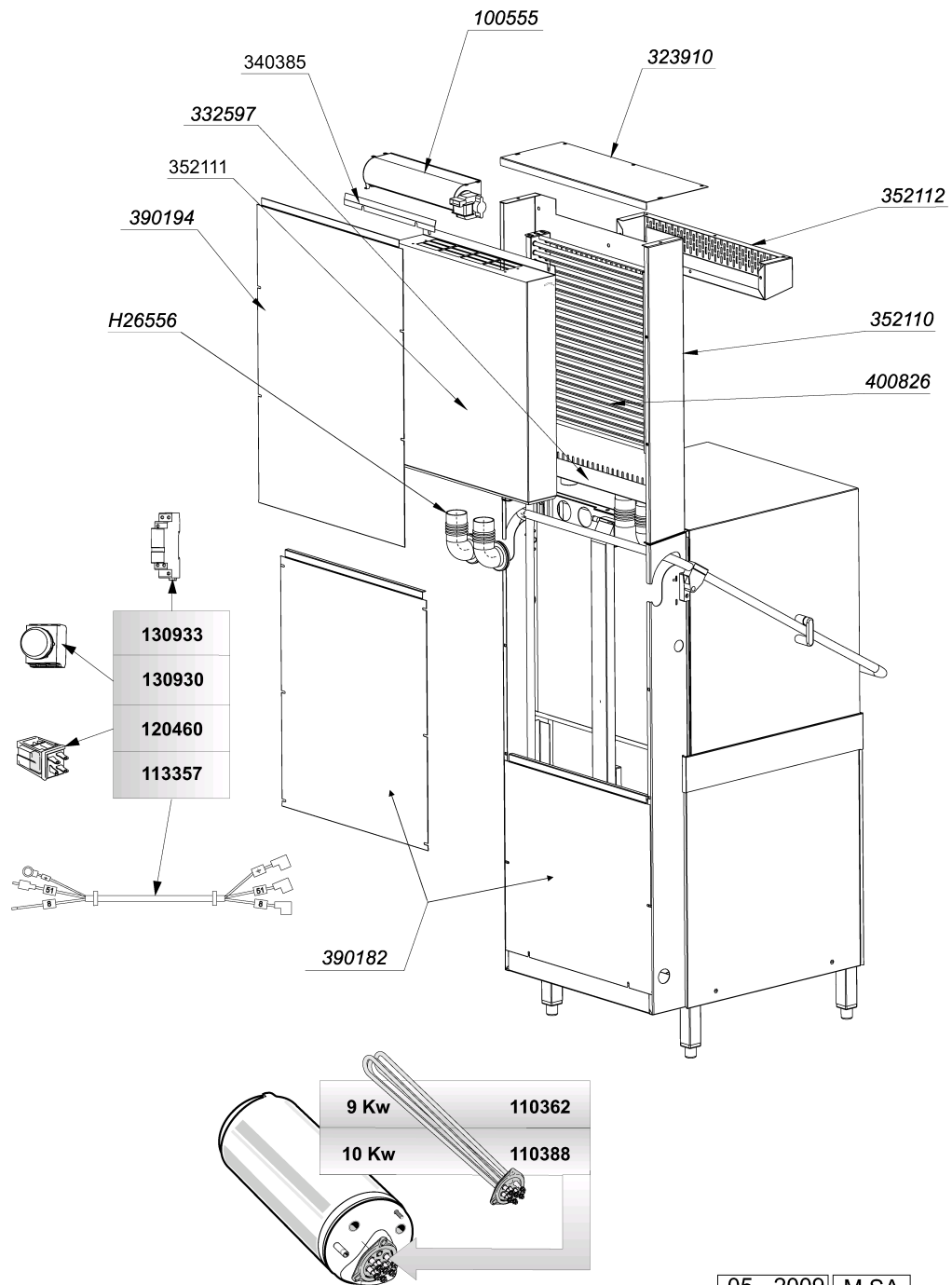

CODE	DESCRIPTION
100555	FAN TGA60/1 360-30
110362	HEAT.ELEMENT 9000W 220/380V
110388	HEAT.ELEMENT 10000W 230/400V
113357	CABLE FOR CRC
120460	RELAY 16A 220V
130930	CONTACT ABB 1NO/1NC 180"
130933	SUPPL. CONTACT NO/NC ABB
323910	CRC UPPER COVER
332597	COLLETTORE ASPIRAZ. CRC C2001
340385	PARATIA VENT."POST" CRC C2001
352110	BACK PANEL
352111	BACK PANEL CRC
352112	FRONT COVER CRC
390182	BACK PANEL
390194	BACK PANEL CRC
400826	CRC BATTERY
H26556	HOSE